

Angle Mount for VTL G3 (2ft and 4ft)

Inside the box

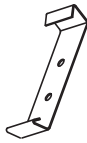

(2) Bracket A



(2) Bracket B



(2) Shrapnel



(8) M4*12 Screw



(8) Expansion Screw



(2) M4*25 Tapping Screw

45° Angle

1-1

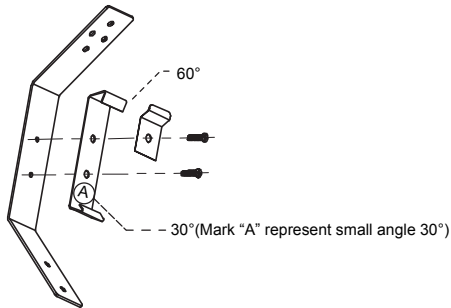

Assemble each bracket with (2) M4*12 screws in order and direction as picture shown.

1-2

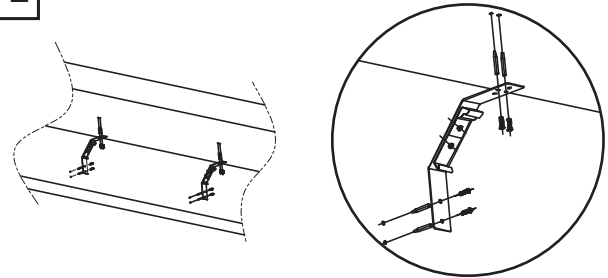

Attach the bracket to mounting surface with (8) expansion screws and (8) M4*25 tapping screws.

1-3

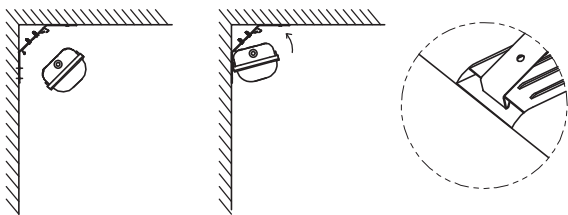

Attach the fixture to the bracket from up to down.

1-4

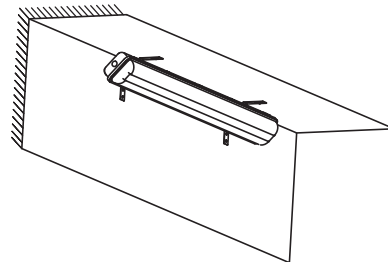

Completed. Please make sure the fixture is locked.

90° Angle

2-1

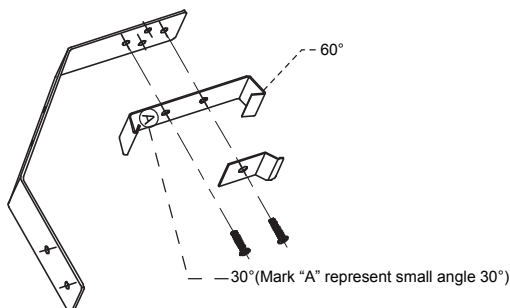

Assemble each bracket with (2) M4*12 screws in order and direction as picture shown.

2-2

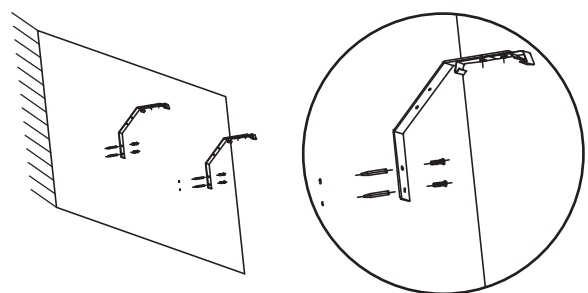

Attach the bracket to mounting surface with (8) expansion screws and (8) M4*25 tapping screws.

2-3

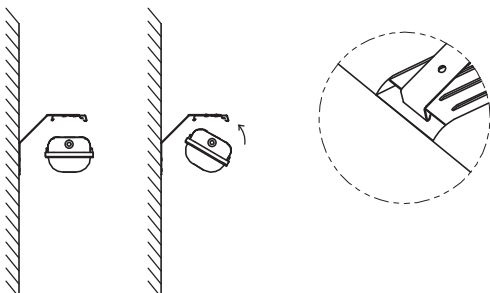

Attach the fixture to the bracket from up to down.

2-4

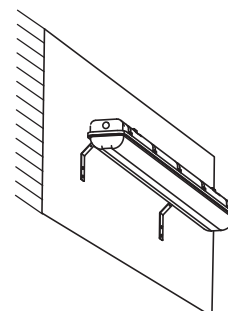

Completed. Please make sure the fixture is locked.